

CONTINUOUS MOUNTING ON CONCRETE CSB SYSTEM

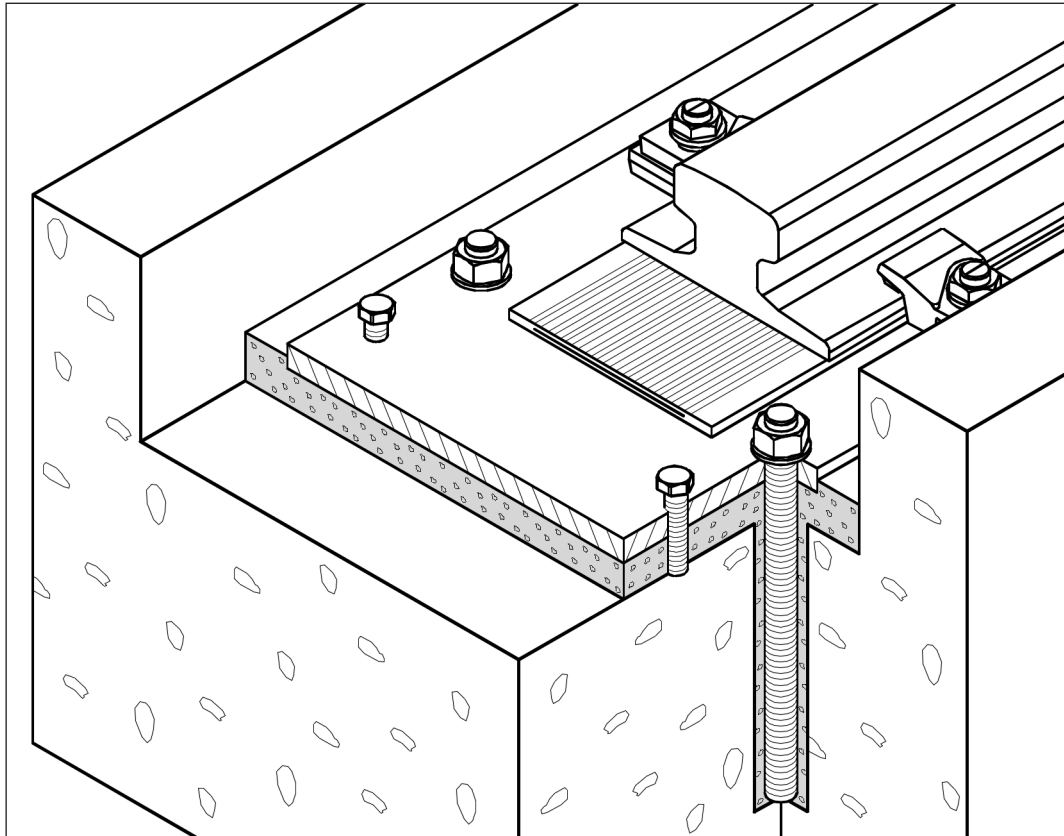

Rail track fastening on concrete support can be made in various ways, either continuous or discontinuous. This data sheet gives the features of an installation with continuous support. For this type of installation, the rail is continuously supported by a sole plate anchored in the concrete.

General characteristics

The patented **GANTREX®** fastening system of soft mounting of crane tracks comprises two components. Firstly, a range of pads which are laid under the rail, and secondly, a series of clips for fastening the rail.

The track support consists of steel sole plates of adequate size. These plates are anchored in the concrete by means of holding down bolts.

The rails are butt-welded. They are laid on their whole length on **GANTREX®** MK6 pad mounted on the sole plates.

After the plates are levelled, the gap between sole plates and concrete is filled with a casting product, such as non-shrink grout or resin.

This type of installation is suitable for heavily loaded tracks, vertical and side loads being widely spread over the concrete.

GANTREX® weldable clip system allows quick rail replacement without any damage to the supporting structure.

Sole plate size, type and spacing distance of holding down bolts and clips are defined taking into account the crane characteristics, as well as rail and support design.

An individual calculation sheet can be issued on request.

Components

SOLE PLATES

Sole plates are available up to a length of about 6 metres. Each sole plate is drilled to accommodate holding down bolts and possibly fixing screws for boltable clips, and may be equipped with various levelling devices.

Sole plate width and thickness are defined based on load and rail foot dimensions.

The plates are made of S235 JR-steel and can, as an option, be protected either by hot dip galvanizing, metallization or painted.

CLIPS

All clips types can be used. The most commonly used are those from series 21 and 22 as their lower part can be welded off site when preparing the sole plates. In this instance, as all work is carried out from above the plates, no access to the undersides is necessary. Please refer to the data sheet "Patented Weldable clips" for further information.

The clip spacing will be specified by our Technical Department, taking into account the specific installation data. Usually this distance varies between 500 and 750 mm.

PAD

As the mounting is of the continuous type, GANTREX® pad type MK6-RB, or MK6-RF is used (see the specific MK6 pad data sheet).

ANCHORINGS

Various holding down bolts can be used, for instance :

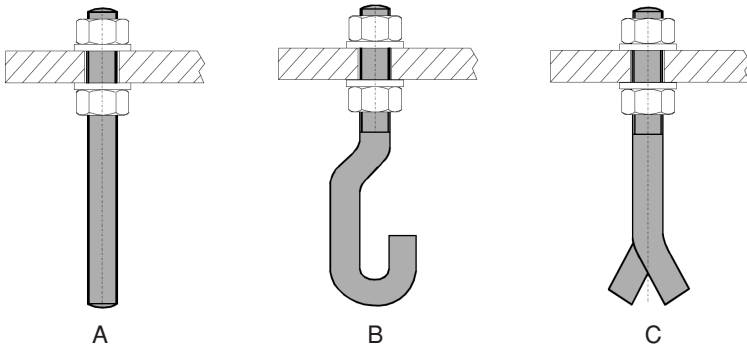

A : threaded rod DIN 976
B : hook type DIN 529 B
C : fish-tail type DIN 529 C

LEVELLING DEVICE

Two systems are commonly used :

- on anchorings : by means of steel nut and soft washer height adjusted on anchor bolts below sole plates.
- with independent bolts : used simultaneously with locking nuts on the holding down bolts.

PROTECTION AGAINST CORROSION

A protection against corrosion, after sandblasting Sa 2,5 may be undertaken either by hot dip galvanizing or by paint or metallization.

• Hot dip galvanizing

Sole plates and lower parts of welded clips can be protected by a 70 µm zinc coat.
Other clip components are supplied galvanized.

• Paint

On request, various paint or metallization types can be proposed ; however, this protection can only take place after complete installation.

Cleaning using solvents is prohibited (please refer to the data sheets “Patented Weldable Clips” and “Patented Bolttable Clips” for further information).

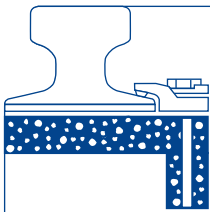

MOUNTING ON CONCRETE



Advice on installation

These recommendations only give general guidance on continuous installation. A detailed method statement can be issued by our Technical Department.

1. Holding down bolts installation. Holding down bolts should be cast in to half their height :
 - either in the concrete poured in first phase;
 - or with resin in drilled holes;
 - or with non-shrink grout in pre-cast boxes or drilled holes.Bolt positions can be made using a template or by using the plates hung under the rail.
2. After casting in the bolts :
 - position and level the sole plates,
 - install the rail pads,
 - install the rails : the rail sections should be butt-welded to make a continuous rail,
 - install and hand-lock the GANTREX® clips,
 - complete joints in the rail by grinding.
3. Final levelling and alignment of the rail.
4. Final grouting around the holding down bolts and sole plates with non-shrink grout or resin.
5. Tighten the holding down bolts and clips to the required torque with a correctly calibrated torque wrench (see specific data sheet for each clip). The use of an impact wrench is not recommended.
6. If required, the complete installation can be given a protective coating. However, in this case, the use of solvent is prohibited, and the clip nose must not be painted.
7. Issue of a track survey report in accordance with applicable standards.

For more information, please consult us.

We reserve the right to discontinue or change specifications or design at any time without prior notice and without incurring any obligation whatsoever.



GANTREX S.A.

rue du Commerce 19 • 1400 Nivelles • Belgium

Tel. : +32(0)67.88.80.30 • Fax : +32(0)67.21.63.21 • E-mail : info@be.gantry.com

<http://www.gantry.com>