

DISCONTINUOUS MOUNTING ON CONCRETE DSB SYSTEM

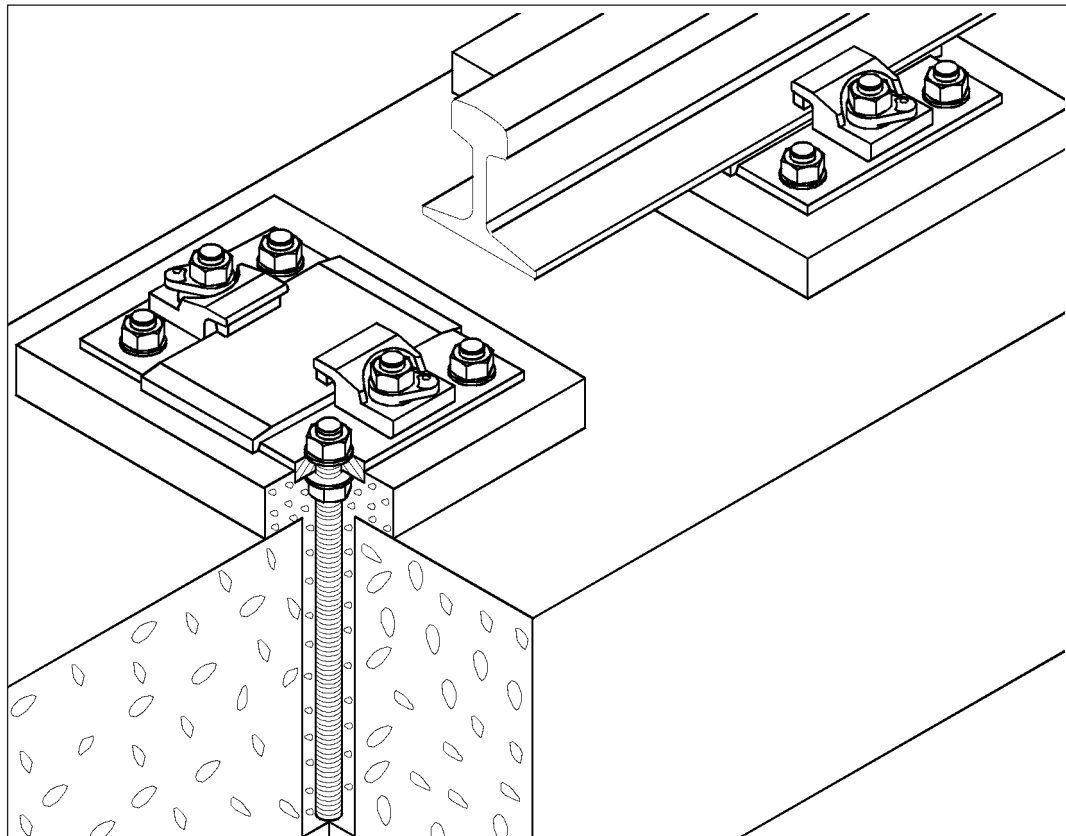

Rail track fastening on concrete support can be designed in various ways. Among these, the discontinuous mounting is widely used, typically in automatic warehouses. For this type of installation, the rail is supported at regular intervals by steel plates anchored into the concrete.

General characteristics

The patented **GANTREX**[®] fastening system of soft mounting of crane tracks comprises two components. Firstly, a range of pads which are laid under the rail, and secondly, a series of clips for fastening the rail.

The track support consists of **GANTREX**[®] chairs anchored by means of holding down bolts.

Steel plate size, clip type, number and type of holding down bolts, as well as chair spacing depend on crane characteristics, loads and rail type.

After levelling, the gap between steel plate and concrete is filled with a non-shrink grout or resin.

The rails are butt welded. They are laid discontinuously on **GANTREX**[®] MK2 pads installed on each steel plate.

Rails are fastened by **GANTREX**[®] adjustable clips.

The chairs efficiently distribute the horizontal loads to the concrete by means of several holding down bolts.

An individual calculation sheet can be issued on request.

The soft mounting system eliminates the fatigue effect on the fastening and reduces the maintenance to a minimum.

Components

STANDARD CHAIRS

Selection of the chair is dependent on :

- horizontal and vertical wheel loads;
- type and quality of concrete support;
- type of application and conditions of use.

Standard chairs are D 414, D 415 and D 419.

	D 414	D 415	D 419
Chair dimensions : <ul style="list-style-type: none">• in the rail axis• width perpendicular to the rail• thickness	110 mm adapted to the rail foot width 12 mm	160 mm adapted to the rail foot width 12 mm	220 mm adapted to the rail foot width 15 or 20 mm
Holding down bolts : <ul style="list-style-type: none">• quantity• diameter	2 M16	2 M16	4 M20 or M24
Clips : <ul style="list-style-type: none">• quantity• type (boltable)	2 41/035 fastened on the holding down bolts	2 41/035	2 41/075 or 41/125
Pad :	MK2-110B	MK2-160B	MK2-220B

Other chairs are available or can be designed. Each specific chair description comprises :

- the components : steel plate, clips, pad, complete anchors, levelling device.
- the dimensions in relation to the rail type.

ANCHORINGS

Various holding down bolts types can be used, for instance :

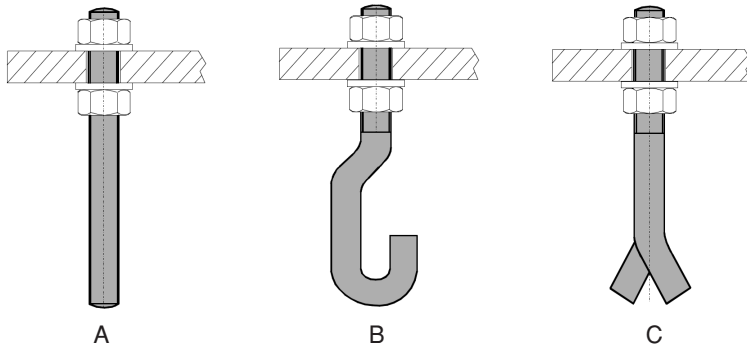

A : threaded rod DIN 976
 B : hook type, DIN 529 type B
 C : fish-tail type, DIN 529 type C

ANCHOR BOXES

For new installations, pre-cast anchor boxes are recommended.
 Boxes will have the following dimensions :

	M16	M20	M24
Diameter (D)	60 mm	60 mm	60 mm
Height (H)*	150 mm	200 mm	250 mm

* indicative values only

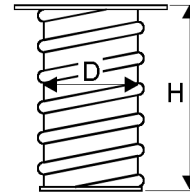

TIGHTENING TORQUES

Tightening torque for holding down bolts and clip bolts are related to the bolt and to the non-shrink grout or resin qualities.

		Torques in Nm		
		M16	M20	M24
Holding down bolts	4.6	70*	135*	235*
Clips fixings	4.6	80	150	250
	5.6	100	200	300
	8.8	200	400	660

* indicative values only

The tightening torque of the fixing bolts determines clip resistance to horizontal loads. Refer to the specific clip data sheet on this subject.

PROTECTION AGAINST CORROSION

Chair components (clips, bolts and steel plate) may be protected against corrosion by hot dip galvanizing 70 microns (other protection type on request). In case of further protection by painting, this can only take place after complete installation, and the use of solvent is prohibited (see also specific sheets BOLTABLE PATENTED CLIPS).

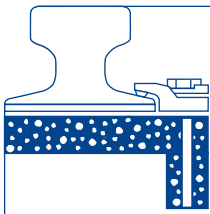

Selection of chair spacing

Chair spacing distance will be calculated for each installation taking into account loads, track geometry, and maximum admissible stresses in the rail.

As a guide, the nominal spacing distance is 650 mm. This must then be adapted to the individual travelling speed and driving group of the crane, and whether guide rollers are fitted, etc...

Only a detailed calculation can take into account the real working conditions and be considered as the detailed application specification.

Advice on installation

These recommendations only give general guidance on discontinuous installation. A detailed method statement can be supplied by our Technical Department.

1. Works preparation – Preliminary visit on site.
2. Holding down bolts installation. Holding down bolts should be cast in to half their height :
 - either in the concrete poured in first phase;
 - or with resin in drilled holes;
 - or with non-shrink grout in pre-cast boxes or drilled holes.

Bolt location can be made using a template or by using the chairs hung from the rail.

3. After casting in the bolts, position and level the steel plates, installing the rail pads, clips and rail. The rail sections should be butt-welded to make a continuous rail. The rail joints are then ground.
4. Final levelling and alignment of the rail.
5. Final grouting around the holding down bolts and chairs with non-shrink grout or resin.
6. Securing the holding down bolts and clips to the required torques with a correctly calibrated torque wrench (see specific data sheet for each clip). The use of an impact wrench is not recommended.
7. Possible protection of the whole installation by paint.
8. Issue of a track survey report in accordance with applicable standards.

For more information, please contact us.

We reserve the right to discontinue or change specifications or design at any time without prior notice and without incurring any obligation whatsoever.



GANTREX S.A.

rue du Commerce 19 • 1400 Nivelles • Belgium

Tel. : +32(0)67.88.80.30 • Fax : +32(0)67.21.63.21 • E-mail : info@be.gantry.com

<http://www.gantry.com>