



The solution for rail track girders fastening



The GANTREX® surge connector, or tie-back, is an answer to the ever present problem of cracks and breaks at joints between girders and columns.

The transfer of side loads from track girders must happen through a girder-column link, which allows relative displacement.

The GANTREX® surge connector allows longitudinal stress transfers along with movements due to the flexing of girders : rotation and translation.

The surge connector eliminates diaphragms and the associated maintenance and repair costs.

Easy and secured installation.



General characteristics

- The GANTREX® surge connector consists of a steel plate provided with two spherical bearings in hardened steel, ensuring a low friction coefficient and requiring no maintenance.
- The bearings can allow a rotation up to 5 degrees due to girders deflections, which, taking account of the length of the surge connector, is always compatible with relative movements inherent in building structures.
- The surge connectors are supplied with O-rings, which protect the bearings by preventing dirt entering the joint.
- The GANTREX® surge connectors fit easily in the global design of the building.

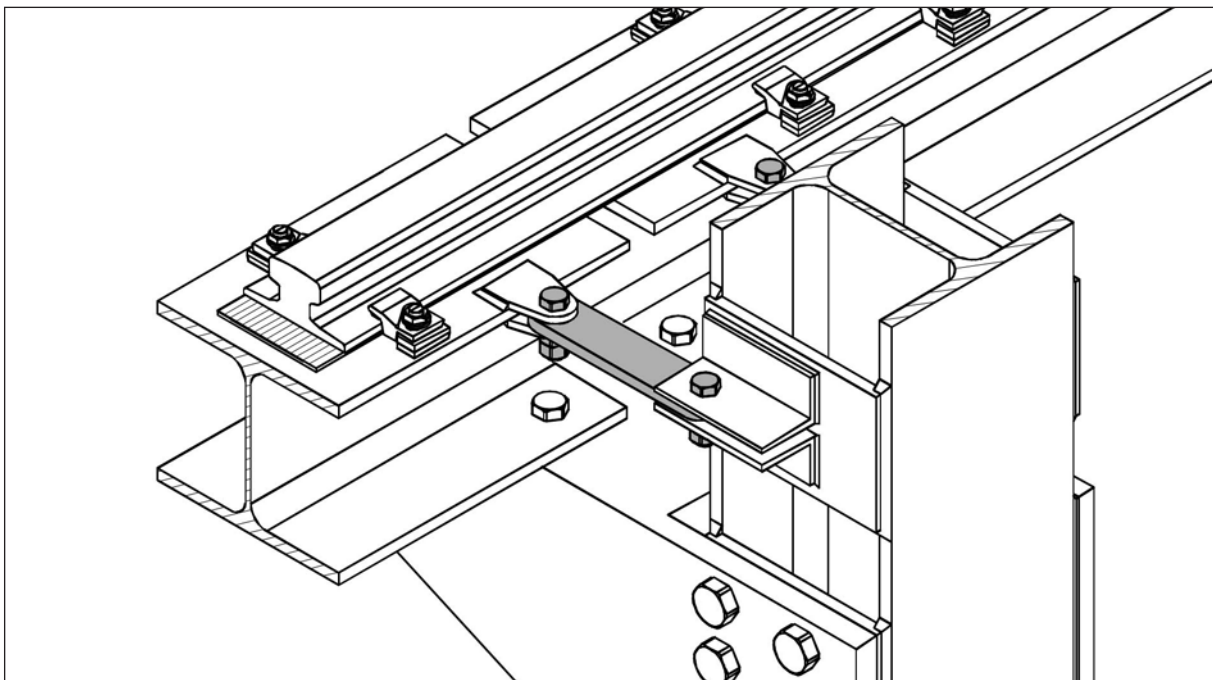

GANTREX's complete range of surge connectors sizes and admissible loads can comply with installation requirements.

The GANTREX® surge connectors can be supplied pre-assembled complete with their fixing support.

Technical data sheets and mounting examples available on request. Our offices are at your disposal for designing the most appropriate assembly.

We reserve the right to discontinue or change specifications or design at any time without prior notice and without incurring any obligation whatsoever.



GANTREX.S.A.

rue du Commerce 19 • 1400 Nivelles • Belgium
Tel. : +32(0)67.88.80.30 • Fax : +32(0)67.21.63.21 • E-mail : info@be.gantry.com
<http://www.gantry.com>